

# IPCO ANCHOR STRAPS

## 1. Product Name

IPCO Anchor Straps

## 2. Manufacturer

Illinois Products Corporation (IPCO)  
423 Joseph Drive  
South Elgin, IL 60177-2268  
800-383-8183; 847-289-2800  
847-289-2804 (fax)  
www.illinoisproducts.com

## 3. Product Description

IPCO Anchor Straps are available in two sizes to adapt to single-course anchorage or double-course anchorage as required.

Shipped flat, the lower arms (a) are spread at right angles during installation and embedded in the concrete masonry bed joint or in cast-in-place concrete. The upper arms (b) are bent to wrap around the sill plate (2"x4", 2"x6" or 2"x8") and nailed to the wood sill.

IPCO Anchor Straps are made of 18 gauge galvanized steel conforming to ASTM A526.

IPCO Anchor Straps should be spaced in the foundation according to local building codes.

For better anchorage and easy installation, the IPCOTE Masonry Anchor Bolt is a better option. IPCOTE Masonry Anchor Bolts are installed in the head joint, providing for stronger, sure anchorage. The bolts won't twist, turn or pull out. See the IPCOTE Masonry Anchor Bolt data sheets for more information.

## 4. Technical Data

- Material: 18 gauge galvanized steel
- Standards: Meets ASTM A526
- Dimensions:  
Single-course anchorage: 14 $\frac{3}{4}$ "  
Double-course anchorage: 22 $\frac{3}{4}$ "  
(see chart at right)

## 5. Installation

The lower arms (a) of the IPCO Anchor Straps are spread at right angles during installation and embedded in the concrete masonry bed joint or cast-in-place concrete. The upper arms (b) are bent to wrap around the sill plate (2"x4", 2"x6", or 2"x8") and nailed to the wood sill.

Spacing is to follow local codes and requirements.

## 6. Availability and Cost

All Illinois Products Corporation masonry products and cost information are available through a nationwide network of masonry and building supply distributors

## 7. Warranty

The recommendations and properties attributed to the products are based upon what is believed to be reliable information. Illinois Products Corporation warrants materials to be of good quality and will replace unused material proven to be defective. No expressed or implied warranty of installed material is made because satisfactory results depend not only on product quality but also upon factors

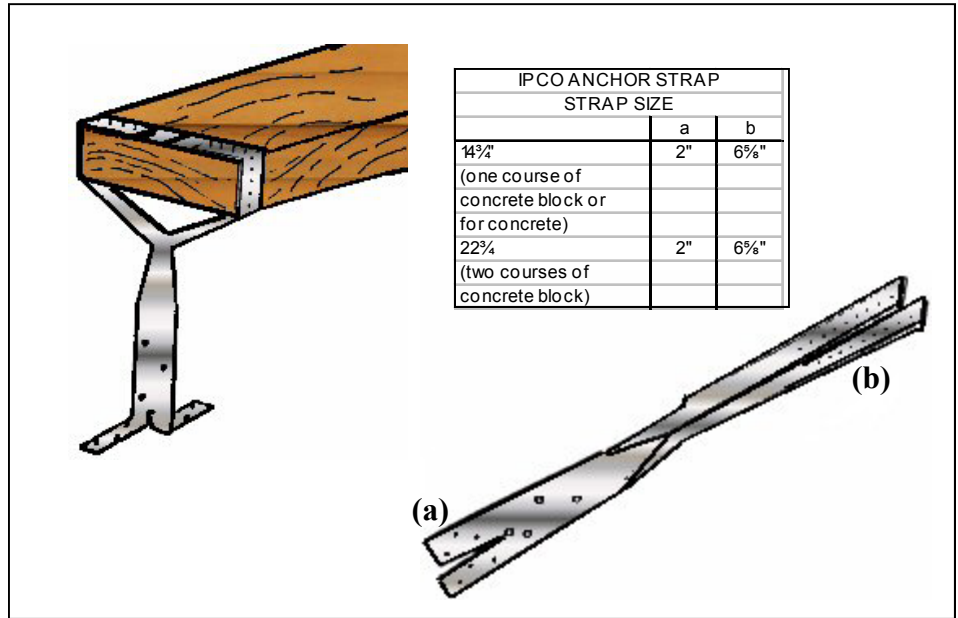

that are beyond IPCO's control.

## 8. Maintenance

No maintenance is required after proper installation.

## 9. Technical Services

Contact the manufacturer for any required technical services. Details and suggested application drawings are available on each individual product data sheet. IPCO Material Safety Data Sheets should be read and understood by all personnel before using the products.

## 10. Filing Systems

Product information is available from the manufacturer in the following formats:

- Complete IPCO product line catalog in printed and CD formats
- Online access to all data sheets at: [www.illinoisproducts.com](http://www.illinoisproducts.com)

Revised 01/2007